

# PULSAR DLCM:

## STROKE LENGTH & VARIABLE SPEED CONTROLLER

The DLCM controller for Pulsar pumps is a significant enhancement to the DLC controller. The DLCM provides the same features as the DLC, with the added capability of motor speed control. Variable speed is accomplished through the use of a tachometer feed back loop controlling a standard DC motor. This combination of variable stroke length and stroke speed control further extends the flexibility and capabilities of the Pulsar pump. The DLCM offers the following:

**Turndown:** A turndown capability of 50:1 (with an accuracy of +/- 1% steady state on set point) is possible when utilizing both variable speed and stroke length on a Pulsar equipped with the DLCM controller.

**Inputs:** The DLCM has the capability of accepting two separate 0-20mA, 4-20mA, 1-5mA or 1-5V DC analog input signals for stroke length and stroke speed control as well as the ability to control both stroke length and stroke speed from a single input signal. Remote START /STOP, level input detection and PULSAlarm leak detection inputs can be configured to stop the pump and / or activate an alarm relay.

**Control Plans:** The ability to select one of the following control plans allows the user to optimize dosing effectiveness:

- Two Analog Inputs:** When two analog input signals are utilized, the signals independently adjust stroke length and stroke speed. Calibration, ratio options, split ranging, direct/reverse action and loss of signal functions (motor shut down or maintain last available analog input signal) and signal isolation are all retained for each of the two analog inputs.
- One Analog Input:** In situations where only one analog signal is available, the DLCM has the capability of being programmed with fixed flow range endpoints for both stroke length and motor speed. This option enables the DLCM to vary either stroke length or motor speed individually or in combination, according to a preprogrammed algorithm. Calibration, ratio options, split ranging, direct/reverse action and loss of signal functions are all maintained with the DLCM when utilizing one analog input signal.
- Manual Mode:** While in manual mode, stroke speed and stroke length respond according to a preprogrammed algorithm. Stroke length and stroke speed will respond according to their fixed flow range endpoints as programmed during the initial pump set up.



**Output:** The DLCM outputs an analog signal that can be programmed to follow the calibrated flow, percent stroke, or percent motor speed. The isolated output signal may be either 0-20 mA, 4-20mA or 1-5mA. Visual indication of pump performance may be displayed in all units of calibrated flow (Metric and English), stroke position or motor speed.

**Calibration:** The DLCM includes an on board program for calibration of both analog input signals to stroke length and motor speed. Up to a five point flow calibration is standard.

**Batching:** As with the current DLC controller, the DLCM maintains the ability to do programmed batching operations, timed interval, and cycle injections.

**Motor Requirements:**

- ◆ Pulsar models 25HJ and 25HL pumps require 1/3 horsepower motors. Either 90V DC or 180V DC motors may be utilized depending on customer requirements. Either 115V AC or 230V AC can be input into the DLCM.
- ◆ Pulsar model 55HL pumps require 1.0 horsepower, 180V DC motors. Because of this, 230V AC input power to the DLCM is required. Consult factory for applications where only 115V AC input power is available.

**Standard Features:**

- DC motor speed control with tachometer feedback
- Manual flow control
- Keypad
- Back-lit 2 line 16 character LCD display
- NEMA 4X enclosure
- Two 4-20mA inputs for independent motor speed and stroke length control
- One 4-20mA output
- 10 Year battery backed clock
- 4 wire RS-485 serial communications port using Modbus protocol
- Solid state alarm relay
- Level input / remote START - STOP inputs
- PULSAlarm leak detection interface
- Self diagnostics

**Approximate Overall Dimensions:**

L	W	H	Approximate Shipping Weight	
			Lb.	(Kg)
Inches	(Millimeters)			
22.75 (574.8)	10.6 (269.5)	Motor Dependant	80 - 100	(36.3 – 45.4)

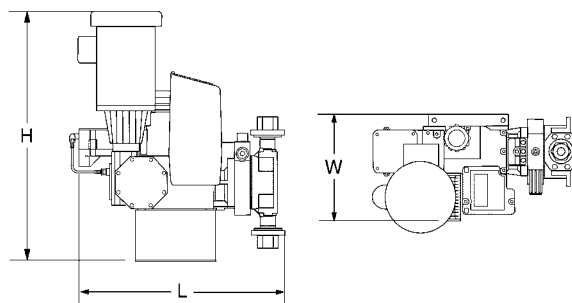

Engineered Pump Operations  
 2883 Brighton-Henrietta Town Line Road  
 Rochester, New York 14623  
 Telephone: (585) 292-8000  
 Fax: (585) 424-5619  
 http://www.pulsa.com – E-mail: [pulsa@idexcorp.com](mailto:pulsa@idexcorp.com)  
 DLCM-TS1103